

## BIG 6 AND FORTRESS LOCKING BAR



**BIG 6 PADLOCK**

The **ERA Big 6 Heavy Duty Padlock** incorporates 6 levers. The cast bolt is housed in a laminated steel case. There are over 1000 key combinations with master keying available. When used with the ERA Fortress Locking Bar, doors up to 70mm thick can be secured.

The **Fortress Locking Bar** has a drill proof hinge-pin which prevents hacksawing, whilst the hardened forged-steel staple, concealed by the hasp, prevents hacksawing and wrenching.

The bars are manufactured from heavy malleable iron castings for maximum strength. All fixing screws are concealed.

### ORDERING DETAILS

#### Big 6 Padlock

73mm (2<sup>7</sup>/<sub>8</sub>" Lock **212-41**

#### Fortress Locking Bar

Fortress **121-41**

The Big 6 Padlock is also available to pass and under a master key.

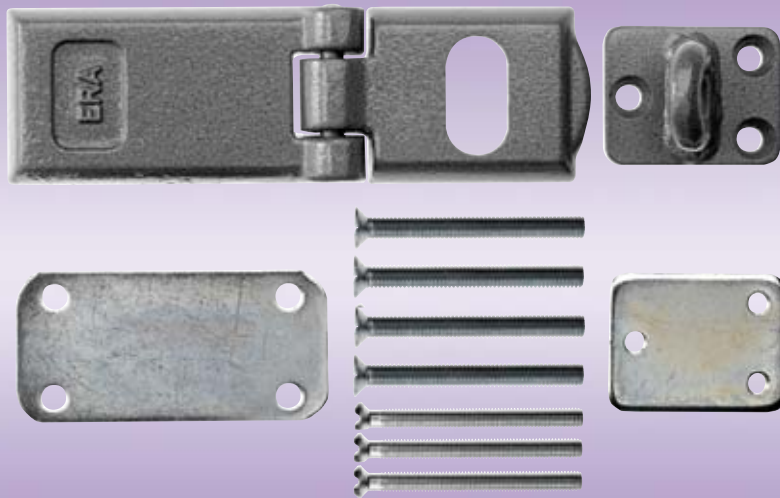

**FORTRESS LOCKING BAR**

Big 6 Padlock

Fortress Locking Bar

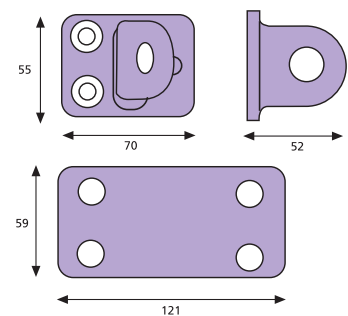
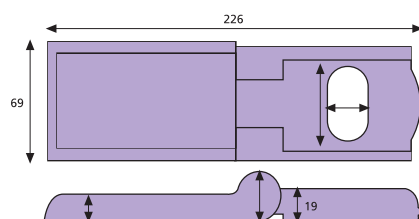
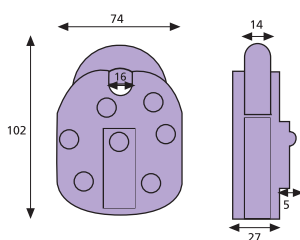

All dimensions in mm.

# CLOSE SHACKLE PADLOCK & NARROW STYLE LOCKING BAR

The **ERA Close Shackle Padlock** has a 5 brass lever locking mechanism with a close hardened steel shackle. Master keying of this product is available. Doors up to 63mm thick can be secured when used in conjunction with the **ERA Narrow Style Security Locking Bar**. This locking bar is manufactured from heavy malleable iron castings for maximum strength. The hardened forged-steel hasp conceals the staple to prevent hacksawing and forced wrenching.

## ORDERING DETAILS

### Close Shackle Padlock

64mm (2 1/2") 5 Lever Padlock **975-91**

64mm (2 1/2") 5 Lever Padlock **975-92**

The Close Shackle Padlock is also available to pass and also under a master key.

### Narrow Style Locking Bar

Narrow Style **125-41**



CLOSE SHACKLE PADLOCK

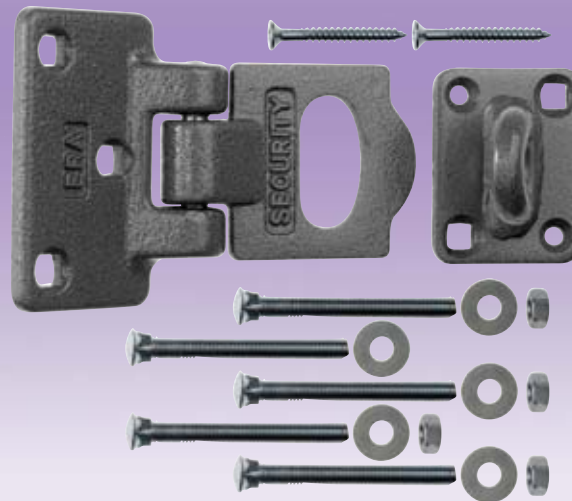

NARROW STYLE LOCKING BAR

Close Shackle Padlock

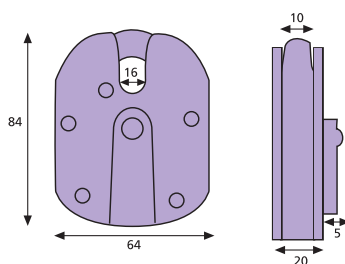

Narrow Style Locking Bar

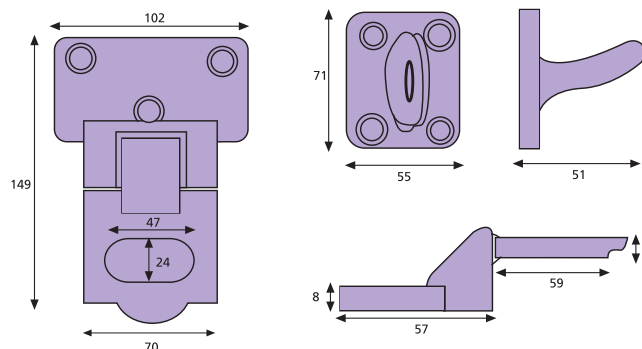

All dimensions in mm.

**BLOCK  
LOCK**

## BLOCK LOCK

The ERA Block Lock is the innovative solution for additional security to safeguard van contents. The Block Lock is easily portable, it can be used on vans, sheds and caravans and no drilling is required. The Block Lock can be fitted in minutes.

One half of the lock, the bracket, is attached to one of the rear doors. The doors are then closed and the locking mechanism is attached to the bracket so that the doors are prevented from opening. The lock uses an oval single cylinder and is opened by key.

### ORDERING DETAILS

Block Lock, boxed 940-85-1

Block Lock, clam pack 940-85-2

Block Lock replacement cylinder 940-61- cylinder

The Block Lock can also be supplied with keys To Pass.



Block Lock

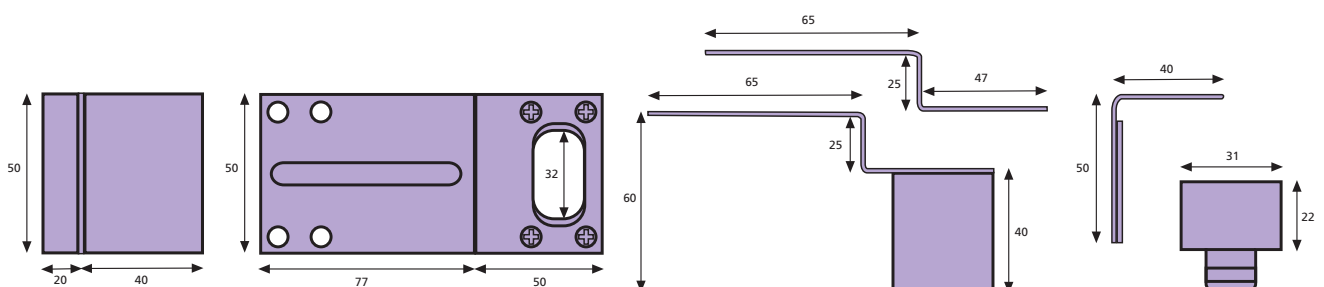

All dimensions in mm.